

Features

SB-CMS-8IN1 8in1 sensor is a multifunctional sensors, many kind of sensor combine to one device like PIR motion sensor, LUX sensor, dry contact, temperature sensor, logic block. It could meet different demand according the different logic. can receive IR code of HDL Remote controller and can send IR code by UV command from itself IR library

- Built in infrared motion sensor, LUX sensor, IR in/out, Dry contact, temperature sensor and external conditions
- 2 logic relations: OR、AND
- 20 Logic module function, can set 6 input conditions, each logic module could set 10 targets for output
- IR transmitter function, 200 IR Emission targets, Universal switch number corresponding from 1 to 200
- IR receiving function, 8 infrared receiving target control, each button can set 10 targets. Note: only can receive HDL remote control
- PIR sensitivity can be adjusted, the sensitivity range of 1-100%
- 20 logics, Universal switch number corresponding from 201 to 240, each logic with two Universal switch number, Universal switch with automatic closing flags and time 1-3600s

Important Notes

- **Detect target** – Only detect moving objects with thermal radiation
- **Bus** - CAT5E or HDL Bus/KNX /EIB Cable
- **Bus Wiring** – Recommended Hand-by-Hand
- **Installation**– indoor and ceiling mount, away AC outlet
- **Temperature**— detecting range of PIR sensor will reduce if the temperature goes high

Product Specifications

- Power supply : DC12-30V
- BUS Power Consumption : 15mA/DC24V
- Detect Diameter : 6m (Installation Height: 2.4m)
- IR Transmit frequency : 38KHz
- IR emission distance : 4m
- Dimension : 80mm (Diameter) ×32mm
- CE Certified
- Working temperature : 0~45°C
- Working Relative Humidity : 20%~90%
- Storage Temperature : -40°C~+55°C
- Storage Relative Humidity : 10%~93%
- Protection Degree : IP20



Safety Attention

- Screw Down strength is less than 0.1Nm
- Do not get wrong connection for bus interface, it will damage the interface of this device .
- Do not get AC power into Bus cable, it will damage other devices in the Bus
- Non-Rain, Non-Contact with other liquids or corrosive gases

Type

SB-CMS-8IN1

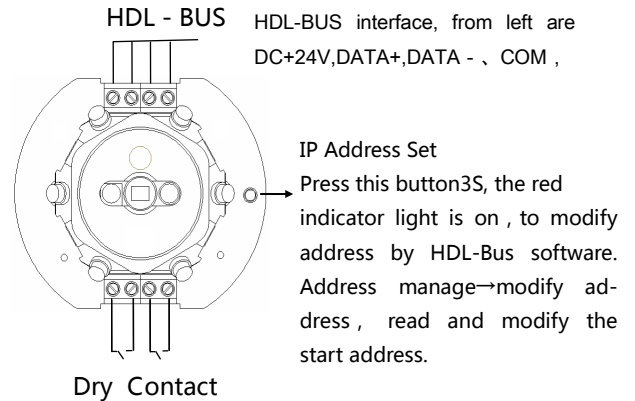
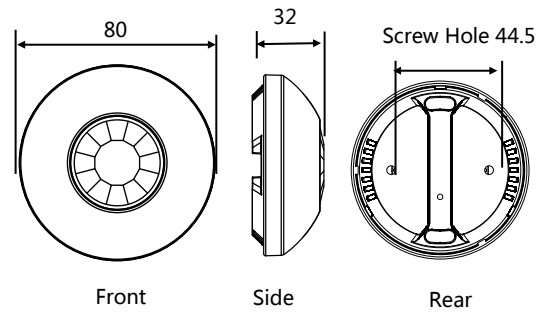

Dry Contact

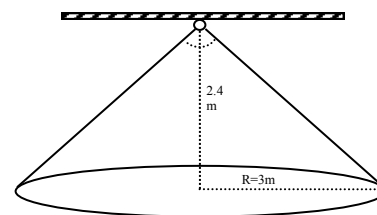
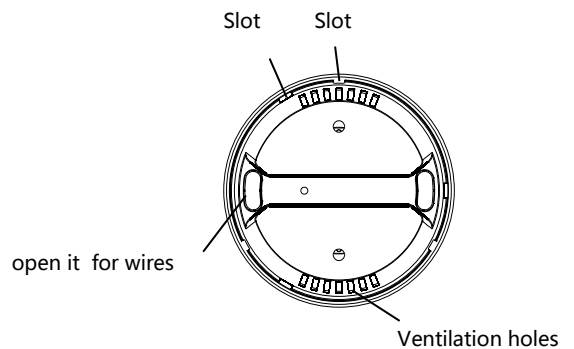

Motion Detect Range

HDL-Bus Definition for cable

CAT5/CAT5E	Bus	HDL Bus/KNX Cable
Blue, White, Orange, White	COM	Black
Blue, White, Green, White	DATA-	White
Blue, Green	DATA+	Yellow
Brown, Orange	DC24V	Red