

Features

HDL - MLED0605.432, 6 channel 5A Intelligent LED Dimming Module can be used to control the LED Light which has constant voltage. It has 6 output channel, each channel has a bypass button for manual control. Scene and sequence functions are available.

- Up to 6 separate areas, max 12 scenes in each area
- Up to 6 sequence , each sequence has 12 steps , running time for each step is 60 minutes, the sequence has 4 running modes: "forward", "backward", "forward and backward", "random"
- Low, high , max threshold for each channel, suitable for different load
- Bypass button for manual control available for each channel
- It is optional setting of choosing a designated scene or back to previous scene when power on again after power off
- Short circuit and over current protection are available
- Max current in Each channel :5A
- PWM Constant Voltage Output

Important Notes

- BUS - HDL Bus/KNX Cable, 0.8mm Single Core Copper cable
- BUS Connection - Series connection (hand by hand)
- Load type -Constant Voltage LED Light , need to connect extra power supply to match the voltage of LED Light.
- Connect checking-Check all connection after installation
- Output channel - Max current in output channel is 5A
- DC24V Input- This is the working power supply for load , the input voltage should be less than DC30V. It is not allowed to use the power from HDL BUS Interface.
- Connection for multi lights- parallel connection

Installation Step

- 35mm Din Rail Installation, inside DB Box
- Connect the Load and Bus cable correctly
- Check the extra DC Power supply, check the voltage and current if match the LED Light
- Check the Bus connection, avoid any mistakes
- Check the load connection, avoid any mistakes

Product Specification

- Working Voltage : DC15~30V
- Dynamic BUS Power Consumption : 40mA@DC 24V
- LED output channel : 6CH/5A
- LED input voltage : 12-30VDC
- Dimension : 144mm×90mm×66mm
- Certification: CE
- Protection Degree: IP20
- Working Temperature : 0~45°C
- Working relative Humidity : 20%~90%
- Storage Temperature : -40°C~+55°C
- Storage relative Humidity : 10%~93%

Type

HDL - MLED0605.432

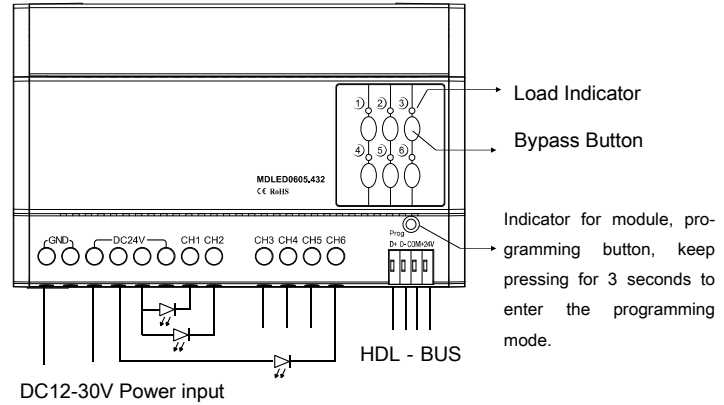

DC12-30V Power input

Note: Take the connection of channel 1,2 and 6 as an example

HDL-Bus Definition for Cable

HDL - BUS Pro	HDL - Bus/KNX Cable
COM	Black
DATA-	White
DATA+	Yellow
DC24V	Red



WARNING

Safety Attention

- Screw down strength is less than 0.4Nm
- LED Light Cable : 2.5 - 4mm² Copper Cable
- Do not make wrong connection on Bus interface, it will damage the Bus interface this module
- Avoid the rain or water into module, it will damage this devices
- Do not get AC240V voltage into Bus wire , it will damage all of devices in system
- Assure a good ventilation circumstances
- Rain, liquid, and aggressive gas are not allowed to close to it